

FOR TAX PURPOSES ONLY

PREPARED BY
RALEIGH COUNTY ASSESSOR'S OFFICE
BECKLEY, WV

RESTRICTION

ALL TAX MAPS CREATED UNDER THE PROVISIONS OF REAPPRAISAL LEGISLATION ARE THE PROPERTY OF RALEIGH COUNTY, WEST VIRGINIA. THE REPRODUCTION, COPYING, DISTRIBUTION OR SALE OF SUCH TAX MAPS OR ANY COPIES THEREOF WITHOUT THE WRITTEN PERMISSION OF THE RALEIGH COUNTY ASSESSOR IS PROHIBITED BY LAW.

REVISIONS
1 12/03/97 CLG
2 01/30/02 CLG
3 11/21/03 CLG
4 09/01/05 CLG
5 01/10/12 TPB
6 10/30/13 BIE
7 01/28/16 KNH
8
9
10

TOWN DIST
BECKLEY CORP

FAYETTE CO
RALEIGH CO

01-17
01-36

LEGEND

- 7TH STREET RIGHT-OF-WAY
- PROPERTY LINE
- ORIGINAL LOT LINE
- DEED LOT NUMBER
- PARCEL OR INDEX NUMBER
- 2016 CHANGE
- BLOCK NUMBER

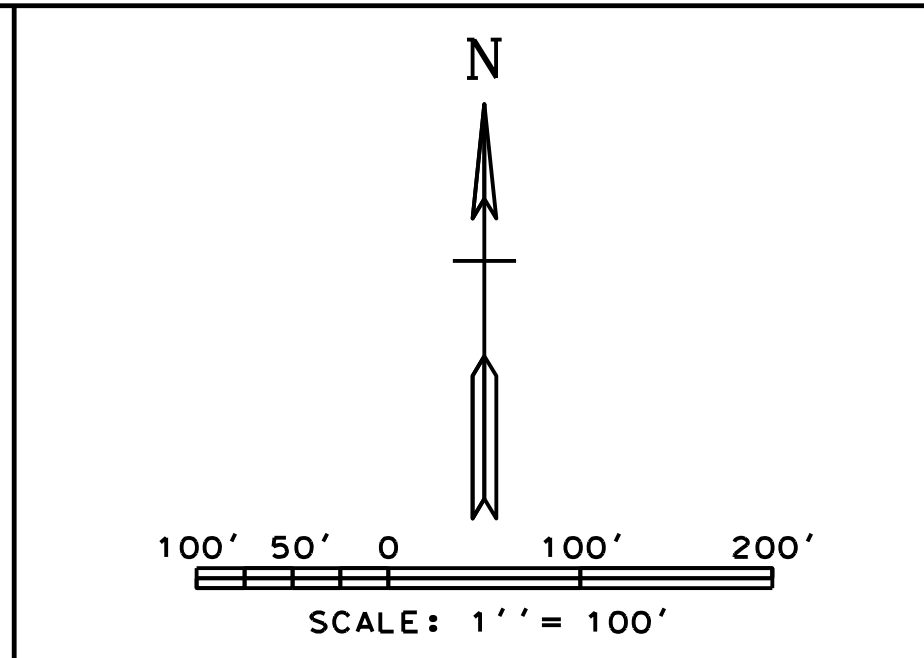

COUNTY OF RALEIGH
OFFICE OF ASSESSOR
BECKLEY, WEST VIRGINIA

BECKLEY CORPORATION
DISTRICT 01
MAP NO. 61