

P/O TOWN DIST  
MAP 12- PAR 1-0

**FOR TAX PURPOSES ONLY**

PREPARED BY  
RALEIGH COUNTY ASSESSOR'S OFFICE  
BECKLEY, WV

**RESTRICTION**

ALL TAX MAPS CREATED UNDER THE PROVISIONS OF REAPPRAISAL LEGISLATION ARE THE PROPERTY OF RALEIGH COUNTY, WEST VIRGINIA. THE REPRODUCTION, COPYING, DISTRIBUTION OR SALE OF SUCH TAX MAPS OR ANY COPIES THEREOF WITHOUT THE WRITTEN PERMISSION OF THE RALEIGH COUNTY ASSESSOR IS PROHIBITED BY LAW.

REVISIONS	
1	12/16/96 CLG
2	04/03/98 CLG
3	02/04/02 CLG
4	09/06/05 CLG
5	06/01/12 PRB
6	
7	
8	
9	
10	

**TOWN DIST**  
BECKLEY CORP

**FAYETTE CO**  
RALEIGH CO

**01-17**  
**01-36**

**LEGEND**

- CORPORATION/DISTRICT BOUNDARY AND NAME
- COUNTY BOUNDARY AND NAME
- ORIGINAL MAP BOUNDARY AND NUMBER
- RIGHT-OF-WAY
- PROPERTY LINE
- ORIGINAL LOT LINE
- DEED LOT NUMBER
- PARCEL OR INDEX NUMBER
- 2010 CHANGE
- BLOCK NUMBER

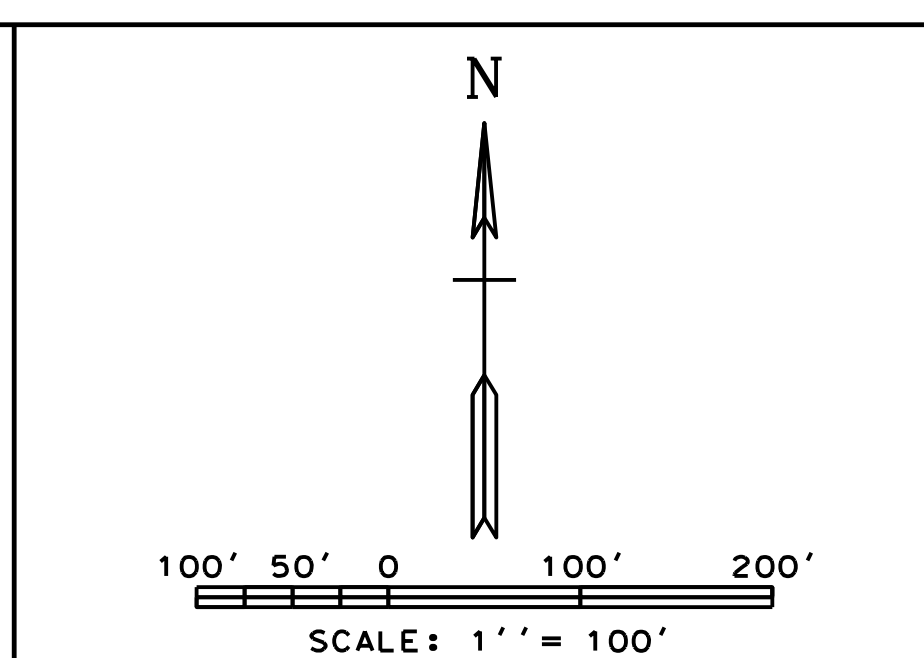

**COUNTY OF RALEIGH**  
**OFFICE OF ASSESSOR**  
**BECKLEY, WEST VIRGINIA**

**BECKLEY CORPORATION**  
**DISTRICT 01**  
**MAP NO. 77**