

**FOR TAX PURPOSES ONLY**  
**LANDMARK**  
 geospatial

Legend	
	District Boundary
	Property
	Road Easement
	Railroad Right of Way
	Road Right of Way
	River
	Deed lot Number (15)
	Parcel or Index Number (9)
	UNKNOWN
	Improvement
	Cemetery
	School
	Church

**Restriction**

All tax maps created under the provisions of reappraisal legislation are the property of the Assessor of Randolph County, West Virginia and the reproduction, copying, modification, distribution or sale of such tax maps or any copies thereof without the written permission of the Randolph County Assessor is prohibited by law.

Revisions			
1	9	17	25
2	10	18	26
3	11	19	27
4	12	20	28
5	13	21	29
6	14	22	30
7	15	23	31
8	16	24	32

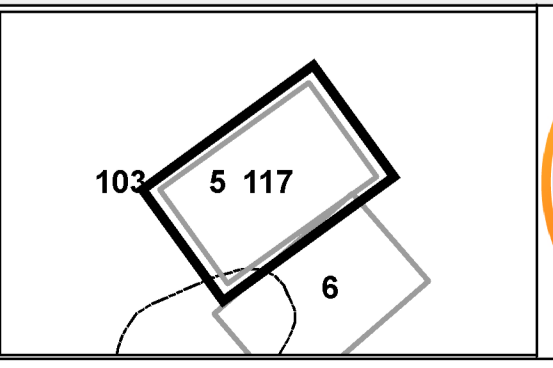

**RANDOLPH COUNTY**  
 Assessor's Office  
 Phyllis K. Yokum, Assessor  
 ELKINS, WV

**LEADSVILLE**  
 District 10 Map No. 5  
 Date of Publication: 01/30/2017  
 Scale: 1"=100'